

## **Memorandum of Understanding on Fibre Optic Testing**

The following is an agreed position by vendors and inspection bodies as to the compliance requirements of infield fibre optic testing in accordance with AS/NZS3080:2003 and AS/NZS/ISO/IEC 14763-3 2007 when published.

### **Background**

The following is the agreed position reached by the Tester/Vendor technical representatives as an industry minimum. It was understood that individual vendors may have more onerous requirements than the minimum contained herein.

AS/NZS3080:2003 and AZS/NZS/ISO/IEC 14763-3 2007 state that the four (4) compliance requirements for testing are:

1. Optical attenuation
2. Propagation delay
3. Length
4. Continuity and maintenance of polarity

AS/NZS3080 Annex B defines compliance testing as a method of validating installed cables, comprising known and unknown components.

The requirements detailed below are the agreed position of all contributing parties to this Memorandum on Understanding on Fibre Optic Testing and reflects the minimum requirements.

To achieve compliance for infield testing the four compliance requirements are to be met and reported.

### **Continuity and Maintenance of Polarity**

- Deemed to be established if testing carried out with a light source and power meter
- Can be established by use of an OTDR with a tail cable. This is conditional on the tail cable being long enough to identify the end connector.

### **Length**

Can be determined by any of the following:

1. Sheath markings
2. OTDR
3. LSPM with length reporting capability

## **Propagation Delay**

Can be determined by:

1. Formula Propagation Delay (ns) = Length (m) x 5ns/m
2. Tester with propagation delay functionality

## **Optical Attenuation**

- All cores are to be individually tested (No Loop Back)
- Unless otherwise specified- permanent link testing will be carried out
- LSPM is the preferred method of determining optical attenuation
- Testing for OTDR and Power Meter and Light source shall be carried out in both directions and a minimum of two wavelengths
- If OTDR testing is utilised to establish optical attenuation of a link or channel when a tail cable will be utilised, the tail cable shall be of sufficient length to establish the loss of the last connector.
- Bi-directional OTDR results can be averaged
- LSPM tests results cannot be averaged.
- The two patch cord test method is not supported

Testing will be carried out using a one or three patch cord referencing/zeroing method. The three patch cord method is the preferred standard.

The light source will have suitable mode conditioning or a qualified mandrel/test cord combination will be used. The method of establishing LMD should be recorded as part of the test documentation.

The launch and tail cord shall present reference connectors at the interface to the link or channel under test.

The LSPM field calibration cord shall have reference connectors at both ends.

The optical attenuation allowance for the two interface connectors of an optical link is 0.3 dB per connector for MM and 0.5dB per connector for SM.

Each link or channel shall have an optical attenuation budget (light budget) calculated for it. The measured loss of the optical attenuation shall not exceed that calculated.

Optical attenuation component values tested with test cords utilising reference connectors				
Wavelengths	Multimode		Single Mode	
Components	850 nm	1300 nm	1310 nm	1550 nm
Cable	3.50dB/km	1.50dB/km	1.00 dB/km	1.00 dB/km
Interface Connectors	0.30 dB per connector	0.30 dB per connector	0.50 dB per connector	0.50dB per connector
Mated Connectors	0.75 dB	0.75 dB	0.75 dB	0.75 dB
Splices	0.30 dB	0.30 dB	0.30 dB	0.30 dB

It was strongly suggested that adaptors with ceramic inserts or other superior quality adaptors be used for testing.

### **Backbone Cross Over**

It was agreed that both crossed and uncrossed backbone cabling systems were utilised in Australia

It was further agreed if keyed duplex connectors were used that cross overs should be used. Additionally if crossovers were used on a site, all installed cable should include a crossover.

# Referencing / Zeroing Method

## 1-Test Cord Method

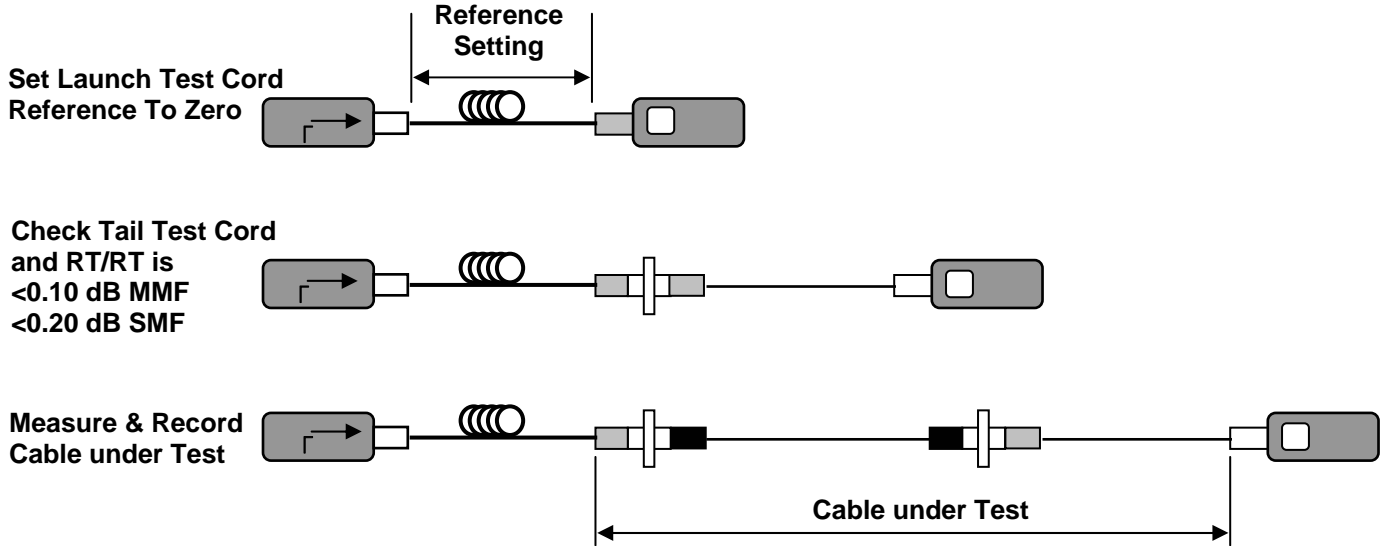

## 3-Test Cord Method

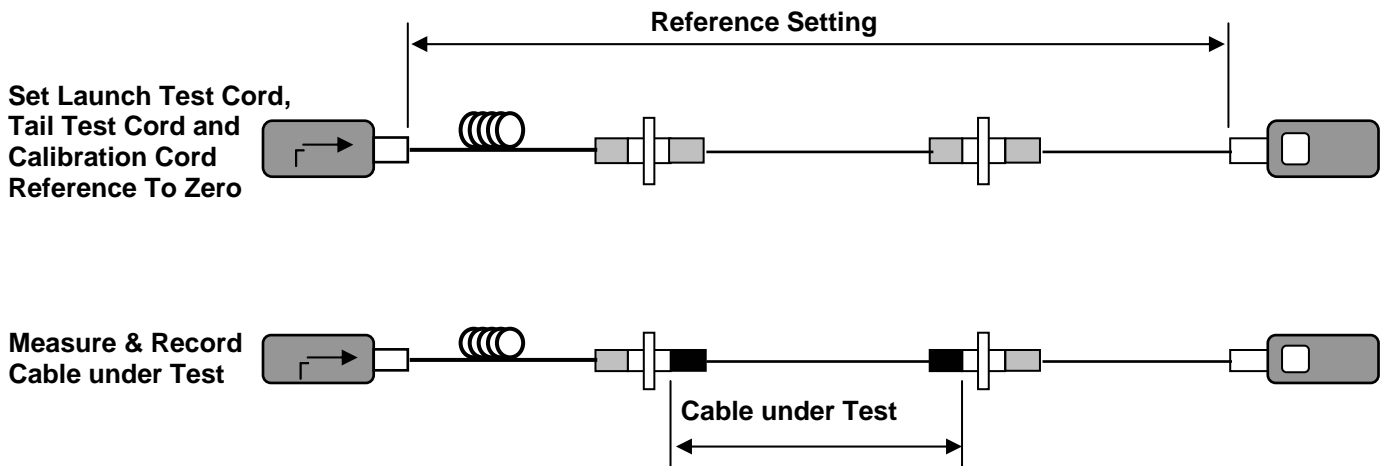

### Legend

- Suitable Adaptor
- Reference Connector RT
- Non-reference Connector NT

This Memorandum of Understanding has been developed and agreed to by the following technical experts.

Murray Teale - VTI Services

Peter Meijer-Krone

Col Browitt-BISCI

Russel Julius- Systimax Solutions

Andrew Kaczmariski-Prysmain

Patrick Attard -TYCO Electronics/AMP

Brad Duce -Siemon

Greg Davies - Siemon

Ian Gale - Panduit

Steve Smithman - Molex

Lui Mollica – Clipsal Australia

Dennis Taarnby – Clipsal Australia

Scott Edwards – Madison Technologies